

Using Nonlinear Optical Networks for Optimization: Primer of the Ant Colony Algorithm

Wenchao Hu¹, Kan Wu¹, Perry Ping Shum¹, Nikolay Zheludev^{1,2} and Cesare Soci¹

¹Centre for Disruptive Photonic Technologies, Nanyang Technological University, 21 Nanyang Link, Singapore 637371

²Optoelectronics Research Centre, University of Southampton, SO17 1BJ, UK
csoci@ntu.edu.sg

Abstract: Using nonlinear Erbium doped optical fiber network we have implemented an optimization algorithm for the famous problem of finding the shortest path on the map for the ant colony to travel to the foraging area.

OCIS codes: (200.0200) Optics in computing; (250.4745) Optical processing devices

Ant colony optimization (ACO) algorithms are inspired by the behavioral pattern of real ants, by which certain species are able to find the shortest path leading to food using indirect communication mediated by modifications of the environment (*stigmergy*). When they find food, ants exchange information by secreting volatile chemicals (*pheromones*) on their way back to the nest. The pheromone increases the probability that other foragers will follow the same path towards the food source, so that ants collectively develop a complex network of trails, connecting the nest to the foraging area in the most efficient way. The network of trails can be seen as a shared memory for the entire colony.

Numerical implementation of artificial ants was first proposed to search for the optimal path in topology graphs, and later found application in various computational problems such as NP-hard combinatorial optimization or routing in dynamic networks [1]. More recently, ACO-based electronic circuits were also proposed for the development of bio-inspired hardware (BHW) able to change its architecture and behavior dynamically and autonomously while interacting with the environment [2].

Here we show an all-optical implementation of the ACO using nonlinear optical fiber networks to represent the graphs. In analogy with artificial ants, the optical power corresponds to the number of ants, transient saturable absorption of Erbium doped fibers mimics the function of pheromone, and an optical reflection mirror is used to represent the food. ACO is demonstrated in two typical design schemes: in a tree-like scheme (Fig. 1(a) and (b)), the path connecting food and nest accumulates the largest optical power (number of ants) compared to other paths, while in a double-bridge scheme where few alternative paths connect the nest to the food (Fig. 1(c) and (d)), the optical output signal from the shortest path is reinforced as a function of time and optical input power.

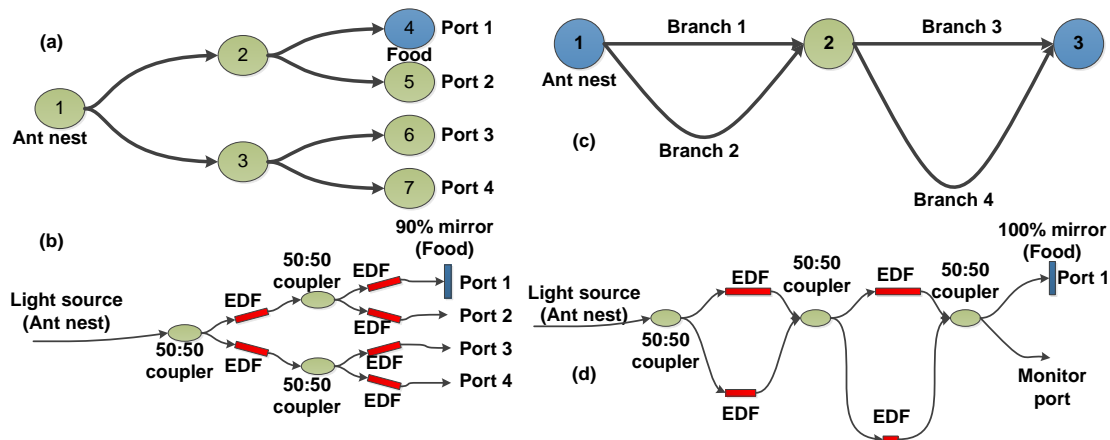

Fig. 1. Network design schemes used to demonstrate all-optical ACO: topology (a) and optical network realization (b) of a two-layer tree experiment; topology (c) and optical network realization (d) of a two-layer double bridge experiment.

In the two-layer, full binary tree topology graph, only one path connects the nest to the food (Fig 1(a)). Here, light is injected into node 1 (ant nest) and a 90% mirror at the output port 1 simulates the food at node 4. A combination of single mode fibers (SMF) and Erbium doped fibers (EDF) with 50:50 couplers is used to implement the graph (Fig. 1(b)): the SMFs determine the length of the branches according to light propagation delay, while EDFs mimic the effect of pheromone by their energy-dependent transmission. With continuous wave (CW) laser input power of 11dBm, the output at port 1 is found to be 0.55dB (11%) higher than that at port 4 (Fig. 2(a)), which is consistent with the simulation results shown in Fig. 2(b). Moreover, with a sequence of laser pulses at the input, pulse power, width and interval can be varied independently to achieve a cumulative saturation regime of transmittance, analog to the effect of each ant's pheromone on the others. In this regime the fiber network reaches the highest transmittance in the path with the mirror (food) over time.

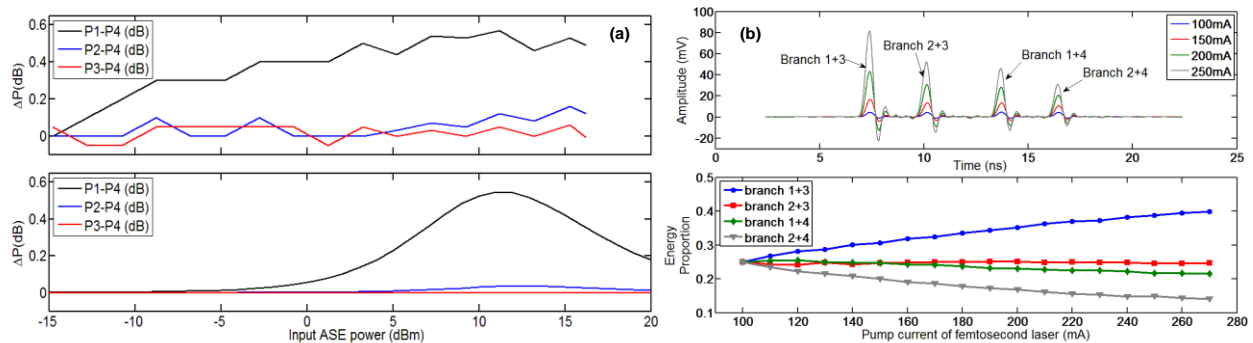

Fig. 2. (a) Experimental (upper panel) and simulated (lower panel) CW optical power at output ports P1, P2 and P3 of the two-layer tree network, relative to P4. (b) Output pulse signal amplitude (upper panel) and intensity dependence of the optical energy (lower panel) for the four paths connecting nodes 1 and 3 in the two-layer double bridge network.

In the two-layer double bridge topology graph, four possible paths (solutions) connect the nest to the food (Fig. 1(c)). In this case the network setup is similar to the two-layer tree, except for the use of EDF lengths which are inversely proportional to the actual length of the branches. Among the four possible paths, the one connecting node 1 to node 3 through branch 1 + branch 3 is the shortest and represents the optimal solution of the graph. In the case of a single pulse input, both pulse intensity (Fig. 2(b), upper panel) and energy proportion (Fig. 2(b), lower panel) show convergence of the network toward the optimal (shortest) path as a function of optical input intensity. With an input sequence of pulses, a nearly 10% change in output intensity of the optimal path can be observed over time, indicating cumulative reinforcement of the shortest path transmission analog to the stigmergic learning capability of the ant colony.

In conclusion, we demonstrate an all-optical experimental primer of the ACO algorithm based on nonlinear fiber networks. We show that in a two-layer tree graph such network can find existence of a path to the food, while in a two-layer double bridge graph the network converges autonomously to the minimal-path solution. Self-learning capabilities of nonlinear optical networks, combined with their possible implementation on integrated silicon photonics or plasmonic platforms, add to the development of “cognitive photonic networks” like the recently demonstrated optical fiber network for the calculation of matrix inversion [3], or the optical fiber network oracle for the solution of NP-complete Hamiltonian path problem [4].

- [1] M. Dorigo and T. Stützle, *Ant Colony Optimization* (2004), The MIT Press, Cambridge, Massachusetts, ISBN 0-262-04219-3
- [2] H. Duan, Y. Yu, J. Zou, X. Feng, *Ant colony optimization-based bio-inspired hardware: survey and prospect*, *Transactions of the Institute of Measurement and Control* 34, 318-333 (2012)
- [3] K. Wu, C. Soci, P. P. Shum, and N. I. Zheludev, *Computing matrix inversion with optical networks*, *Optics Express* 22, 295-304 (2014)
- [4] K. Wu, J. García de Abajo, C. Soci, P. P. Shum, and N. I. Zheludev, *An optical fiber network oracle for NP-complete problems*, *Light: Science & Applications* (2014), in press.